

 **OX**[®]

 **RUD**

LIFTING SOLUTIONS

BEDSAB

MACHINE MOVERS

MODELS

MINIFORCE 30t

ST. 60t - 100t - 150t

TBC. 60t - 100t



**YOUR TRUSTED
PARTNER FOR
HEAVY LIFTING
SOLUTIONS**



MACHINE MOVERS **INDEX**

page 04
MINIFORCE30

page 06
OX-ST 60t — 150t

page 08
OX-TBC 60t - 100t

page 10
ACCESORIES AND SPARE PARTS

page 10
PORTFOLIO

page 11
ROTATING TROLLEYS TECHNICAL FEATURES

page 16
ROTATING TROLLEYS POSSIBLE USES

Do you need more information?

Do you need more information? Looking for an official dealer or reseller? More load tables? More images or pictures?

Check out these websites



MACHINE MOVERS

WHAT IS AN OX SELF-PROPELLED TROLLEY SET

The OX self-propelled Trolleys (or Machine movers) consist of a motorised tool for loading and moving loads, usually to introduce or remove equipment from confined spaces without access to other means such as cranes and therefore represent an ideal equipment to complement a crane in a transport service or relocation of equipment.

The OX self-propelled trolley set consist of two parts which are supplied separately, the self-propelled trolley itself which consists of the load traction element (References ST, TBC or MiniForce) and on the other hand the rear trolleys (Reference CT), which are placed on the other side of the load parallel to each other forming a triangle with the trolley where the load rests.

The support points of the load are covered with rubber and the support point on the trolley is a free turning plate that allows partial or complete unlimited turning on itself, which allows it to turn with a small radius only limited by the adherence of the load on the rear carriages themselves.

The trolleys can have different power sources, battery, main power (220V or 380V) or even both types according to need (TBC and Miniforce). Also, depending on the model, they can have an integrated load lifting system (TBC) or the lifting must be done by additional means (ST or MONIFORCE), either by crane or by hydraulic jacks (you can ask our sales team for further information about hydraulic jacks or hydraulic cylinders).

All self-propelled trolleys are controlled by means of a joystick control via radio control and, as an auxiliary, by means of a cable-operated push-button control.

The maximum speed is slow for safety in order to allow a quick and smooth stop. The value is variable depending on the model and the type of power supply: battery or mains connection, and in this case it also changes whether it is connected to 50 or 60Hz.

The trolleys are designed for horizontal displacements, although due to their geometry and capacity they can face specific slopes of up to 2°, in which case additional load retention systems must be used to guarantee the complete safety of the manoeuvre and under the responsibility of the user of the equipment.

If you need more information, do not hesitate to contact our technical and commercial team.

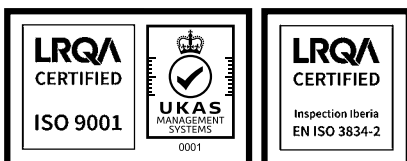



| MODEL | CAPACITY | | POWER SUPPLY | | | | INTEGRATED LIFT (distance) |
|-----------|------------------|---------------|----------------------|-------------|----------|------------|-------------------------------|
| | Pulling Capacity | Load Capacity | RED | BATERÍA | | | |
| Type | | | | Capacity | Autonomy | | |
| MINIFORCE | 30t | 15t | 220V Single-phase | 48V Lithium | 72Ah | 300 minuts | NO |
| ST | 60t | 30t | 400V Single-phase | NO | - | - | NO |
| | 100t | 50t | | | | | |
| TBC | 150t | 75t | 400V Three-phase | 24V Lead | 180Ah | 60 minuts | 70 mm |
| | 60t | 30t | | | | | |
| | 100t | 50t | | | | | |

MACHINE MOVERS
MINIFORCE30
 TECH SPECS

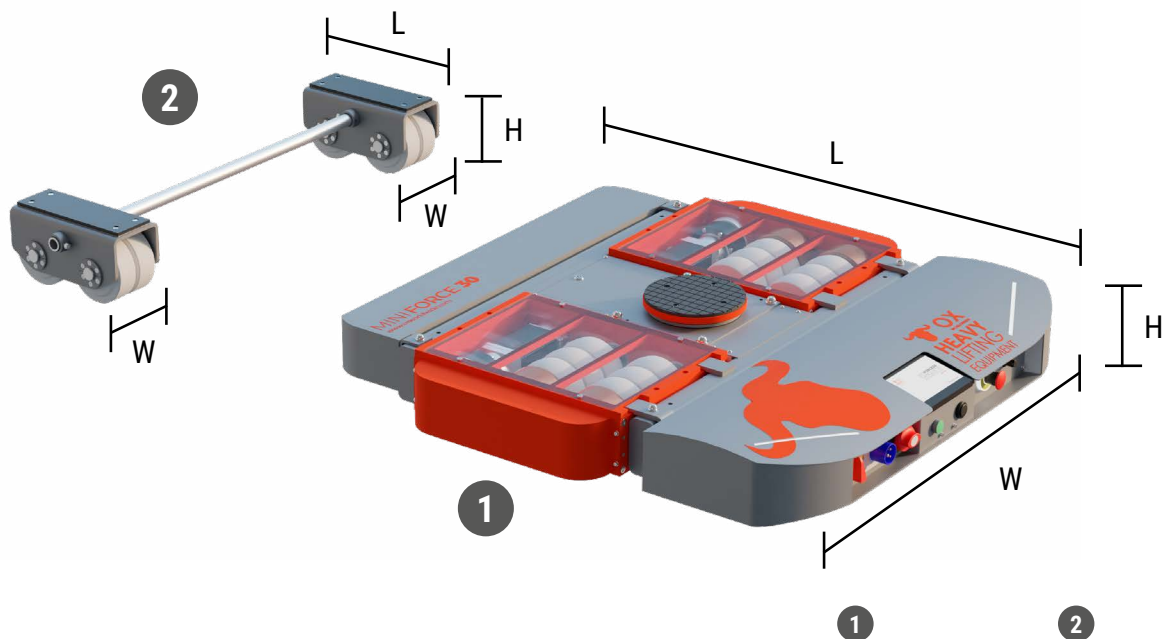

NEW
MINIFORCE30

New model. Self-propelled Trolley with a towing capacity of 30 tons with a height of only 180mm.

The only one in the market able to work either connected to 230V single-phase mains with only 4kw or wireless, by means of integrated lithium batteries.

It has a super-reduced height of only 180mm and is capable of a speed of up to 6.5 m/min with a battery autonomy of up to 5 hours that can be extended indefinitely connected to the mains, in addition, in the connected state, it recharges during standby periods. The full charge takes only 3.5 hours.

Equipped with double joy stick radio control that allows it to turn on itself as a tank without advance, or make turns with movement like a conventional vehicle. It has a tablet with LCD touch screen to manage and control parameters of the trolley, as well as Wi-Fi connection to monitor the status and maintenance remotely via internet.

| MODEL | MINIFORCE30 / STB30 "v2" | PAIR REAR TROLLEYS STB-30 |
|--------------------------|--------------------------------|--------------------------------|
| Code | 801STB2030 | 801CT2030 |
| Load Capacity | 15.000 Kgs | 15.000 kgs/pair |
| Pulling Capacity | 30.000 Kgs | - |
| Number of Castors | 16 | 8 |
| Type of Castors | 4xPU* & 12xPA** | PA** |
| Traction Wheels | 4xPU* | |
| Polyurethane Wheels Size | 150 x 63 mm | 150 x 60 mm |
| Polyamide Wheels Size | 148 x 63 mm | |
| Height (H) | 180 mm | 180 mm |
| Dimensions (LxW) | 1.213 x 1.190 mm | 320 x 183 mm |
| Connecting bar | - | 2 unid Diam. 32 x 1190 mm |
| Support surface | Diam. Turnplate 210 mm | Rectangular plate 310 x 100 mm |
| Weight | 380 kgs | 15 kg |
| Turning radius | 751 mm | - |
| Radio remote control | 1x - Danfoss Mod. TM IK2.MP08V | - |
| Cable Control | 4 m | - |
| A/C Powered | 230 V 50/60 Hz | - |
| D/C Powered | 48 VDC | - |
| Adjustable Speed | 2 speeds and variator | - |
| Max speed | 6,5 mts/min | - |
| Op. Battery time | 5 h | - |
| Charging time | 3,5 h | - |
| Battery type | Lithium 48 VDC 72 AH | - |
| Touch Screen | LCD | - |
| Screen dimensions | 7 Inches | - |
| Screen connectivity | WIFI | - |

*PU: Polyurethane
 **PA: Polyamide

MACHINE MOVERS
MINIFORCE30
FEATURES

Power supply: 230 V Single phase 50/60 Hz.
 48V 72Ah lithium batteries.

High torque and very low consumption servo-
 motors.

Sealed maintenance-free reducer and gear
 transmission.

Mixed wheel system with PA6 Polyamide load wheels
 and Polyurethane traction wheels, providing an ideal
 balance between load capacity and traction.

MINIFORCE30
BLOCK DIAGRAM

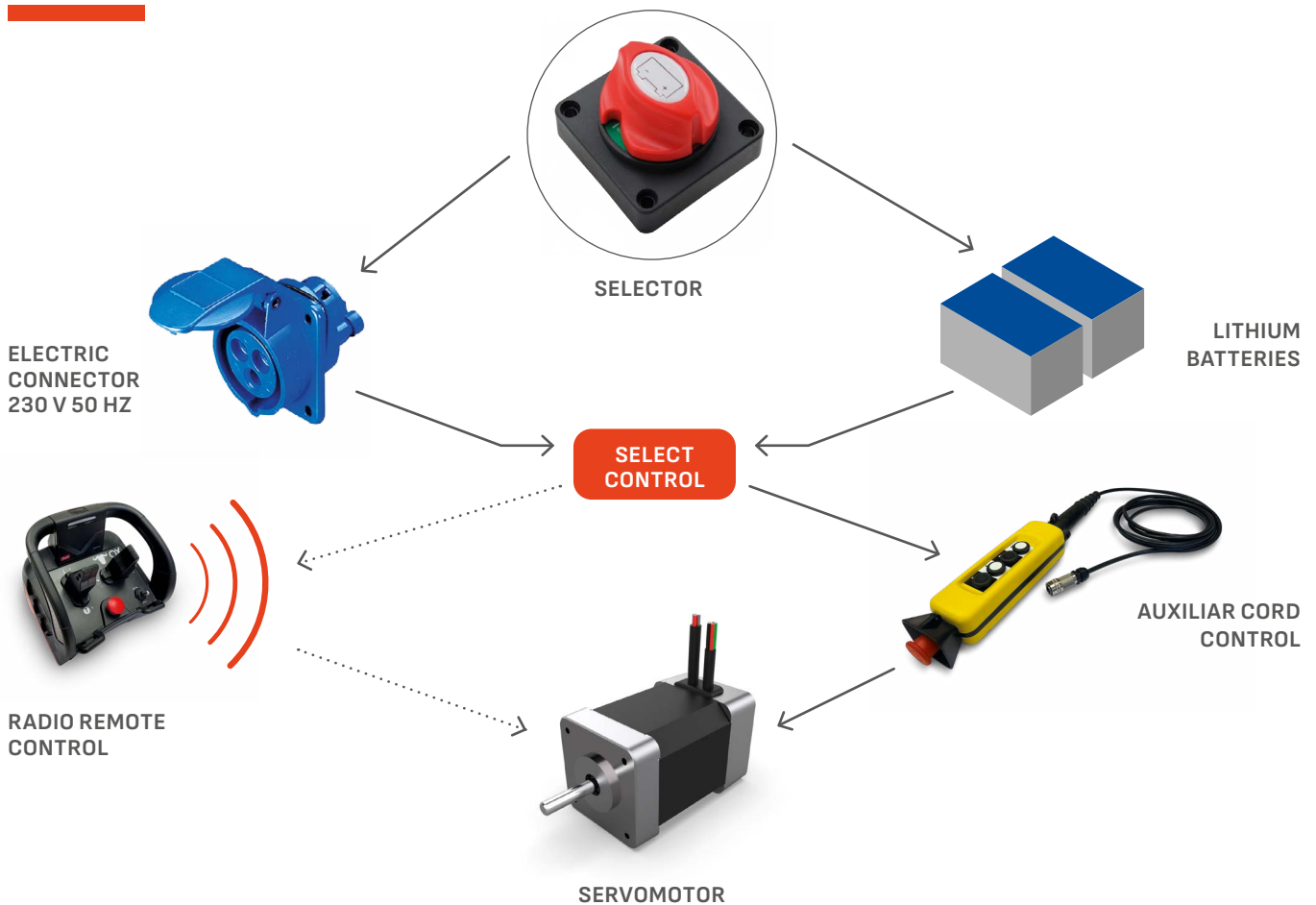

MACHINE MOVERS

OX-ST

TECH SPECS

The ST models are the basic model as they have only power supply without the possibility of battery, direct to mains, specifically three-phase 400V and also has no lifting. Although it has the limitation of use exclusively connected to the mains and requires additional means

for lifting the load, it is a more economical solution but no less capable of supporting and dragging the nominal load without ever running out, so it is an interesting solution to complement the maneuvering of movements of specific equipment.

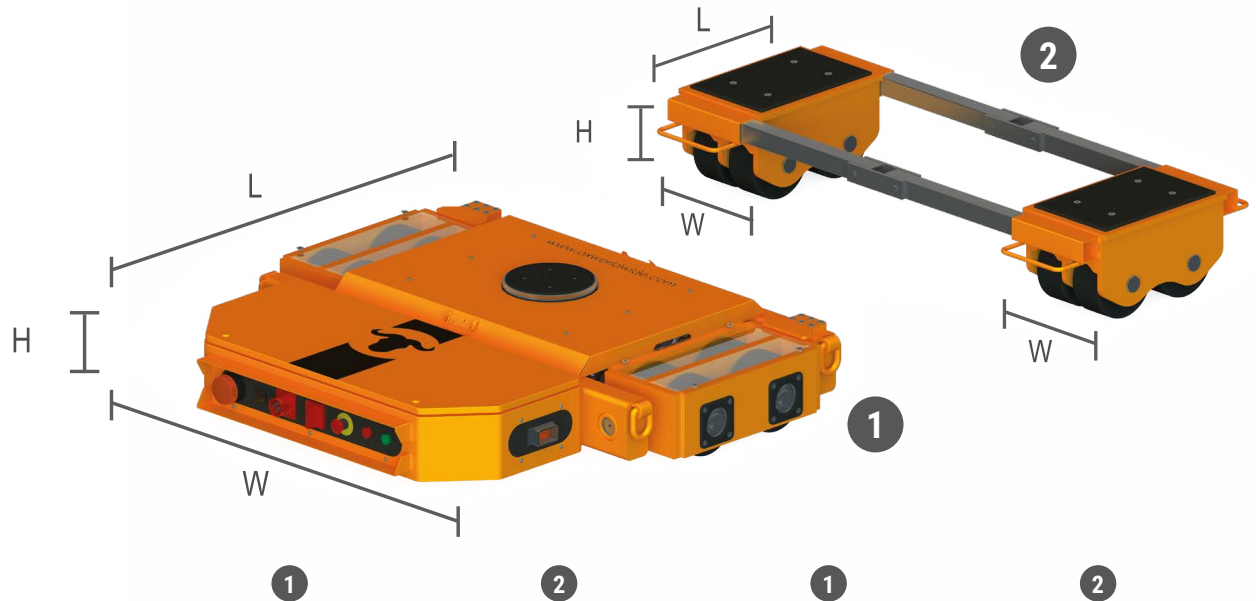

| MODEL | OX-ST-060 V1 | PAIR REAR TROLLEYS OX-CT-060 | OX-ST-100 V3 | PAIR REAR TROLLEYS OX-CT-100 |
|---------------------------------|---|------------------------------|---|------------------------------|
| Code | 801ST1060 | 801CT1060 | 801ST3100 | 801CT1100 |
| Load Capacity | 30.000 Kgs | 30.000 kgs/pair | 50.000 Kgs | 50.000 kgs/pair |
| Pulling Capacity | 60.000 Kgs | - | 100.000 Kgs | - |
| Number of castors | 12 | 12 | 18 | 16 |
| Type of castors | 12xPA* | 12xPA* | 18xPA* | 16xPA* |
| Traction wheels | 12xPA* | - | 18xPA* | - |
| Polyurethane wheels size | - | - | - | - |
| Polyamide wheels size | 200 x 100 mm | 200 x 100 mm | 200 x 100 mm | 200 x 100 mm |
| Height (H) | 302 mm | 302 mm | 315 mm | 315 mm |
| Dimensions (LxW) | 1.509 x 1.520 mm | 371 x 302 mm | 1.582 x 1.919 mm | 497 x 315 mm |
| Connecting bar | - | 50X50 Square 1.200 mm x2 | - | 50X50 Square 1.200 mm x2 |
| Support surface | Diam. Turnplate 283 mm | - | Diam. Turnplate 283 mm | - |
| Weight | 790 kgs | 130 Kgs/pair | 1.070 kgs | 180 Kgs/pair |
| Turning radius | 1.086 mm | - | 1.086 mm | - |
| Radio remote control | 1x - Teleradio PNS-R15141 | - | 1x - Teleradio PNS-R15141 | - |
| Cable Control | 1x | - | 1x | - |
| A/C Powered | 400 V 50/60Hz | - | 400 V 50/60Hz | - |
| D/C Powered | - | - | - | - |
| Adjustable Speed | 1 speed with acceleration & deceleration ramp | - | 1 speed with acceleration & deceleration ramp | - |
| Max speed | 5 mts/min | - | 5 mts/min | - |

Polyamide

MACHINE MOVERS OX-ST FEATURES

Power supply: 400 V III 50/60 Hz.

Compact planetary geared motor with chain and gear transmission between shafts.

Drive by variable speed drives with acceleration and braking ramp.

Polyamide PA6 black wheels.

Speed: Acceleration and deceleration ramp, from 0 to 5 m/min in 3 seconds.

OX-ST BLOCK DIAGRAM



MACHINE MOVERS

OX-TBC

TECH SPECS

The TBC models are the top equipment model as they have both battery and direct power supply, specifically three-phase 400V and also have oil hydraulic elevation (lifting hydraulic cylinder) under the turntable. It can work indistinctly with battery or connected to the mains. It does not require additional means for lifting the load if it is on supports or legs that allow the trolley @to be placed under the load.

It is also a wise decision as it saves on additional equipment such as hydraulic jacks. Likewise, although the battery has limited autonomy, it can be supplied with a double battery or, if necessary, the maneuver can be finished connected to the mains.

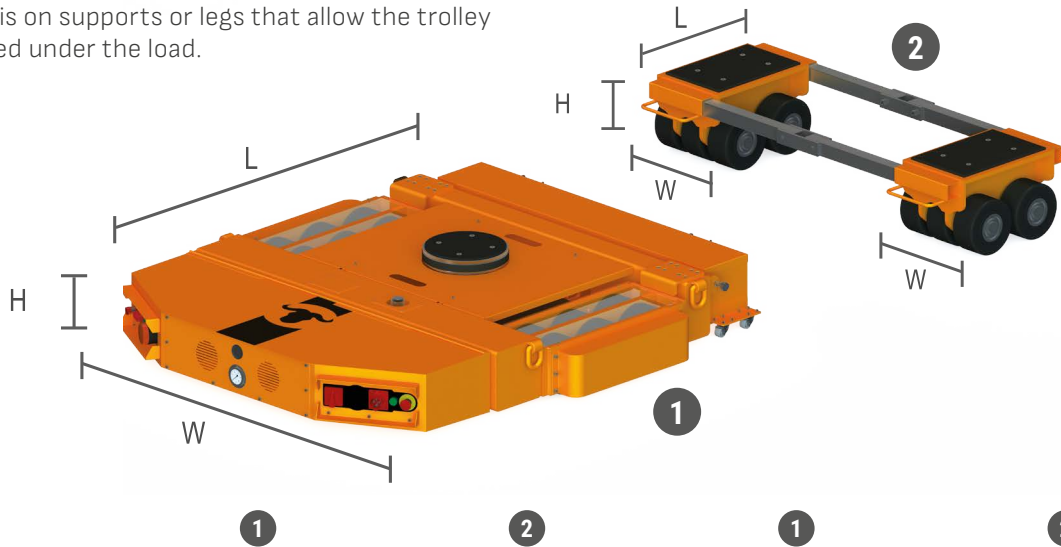

| MODEL | OX-TBC-060 V1 | PAIR REAR TROLLEYS OX-CT-060 | OX-TBC-100 V1 | PAIR REAR TROLLEYS OX-CT-100 |
|---------------------------------|---------------------------|------------------------------|---------------------------|------------------------------|
| Code | 801TBC1060 | 801CT1060 | 801TBC1100 | 801CT1100 |
| Load Capacity | 30.000 Kgs | 30.000 kgs/pair | 50.000 Kgs | 50.000 kgs/pair |
| Pulling Capacity | 60.000 Kgs | - | 100.000 Kgs | - |
| Number of castors | 12 | 12 | 18 | 16 |
| Type of castors | 12xPA* | 12xPA* | 18xPA* | 16xPA* |
| Traction wheels | 12xPA* | - | 18xPA* | - |
| Polyurethane wheels size | - | - | - | - |
| Polyamide wheels size | 200 x 100 mm | 200 x 100 mm | 200 x 100 mm | 200 x 100 mm |
| Height (H) | 302 mm | 302 mm | 315 mm | 315 mm |
| Dimensions (LxW) | 1.882 x 1.678 mm | 371 x 302 mm | 1.880 x 1.934 mm | 497 x 315 mm |
| Connecting bar | - | 50X50 Square 1.200 mm x2 | - | 50X50 Square 1.200 mm x2 |
| Support surface | Diam.Turnplate 283 mm | - | Diam.Turnplate 283 mm | - |
| Weight | 968 kgs | 130 Kgs/pair | 1.095 kgs | 180 Kgs/pair |
| Turning radius | 1.220 mm | - | 1.221 mm | - |
| Radio remote control | 1x - Teleradio PNS-R15141 | - | 1x - Teleradio PNS-R15141 | - |
| Cable Control | 1x | - | 1x | - |
| A/C Powered | 400 V 50/60Hz | - | 400 V 50/60Hz | - |
| D/C Powered | 24 VDC | - | 24 VDC | - |
| Adjustable Speed | 1 speed | - | 1 speed | - |
| Max speed | 4 mts/min | - | 3 mts/min | - |
| Op. Battery time | 1 - 1,5 hrs | - | 1 - 1,5 hrs | - |
| Charging time | 8 hrs | - | 8 hrs | - |
| Battery type | Pure lead batteries | - | Pure lead batteries | - |
| Hydraulic cylinder | 1 x 30.000 kgs WLL | - | 1 x 50.000 kgs WLL | - |
| Cylinder stroke | 70 mm | - | 70 mm | - |

Polyamide

MACHINE MOVERS OX-TBC FEATURES

Power supply: 400 V III 50/60 Hz
 Battery: 24V 180Ah.
 Autonomy: 60 minutes.
 Double hydraulic power pack, powered

respectively at 24V DC and 400V III AC.
 Chain and gear transmission between axles.
 Driven by hydraulic motors with overcenters.
 Polyamide PA6 black wheels.

OX-TBC BLOCK DIAGRAM

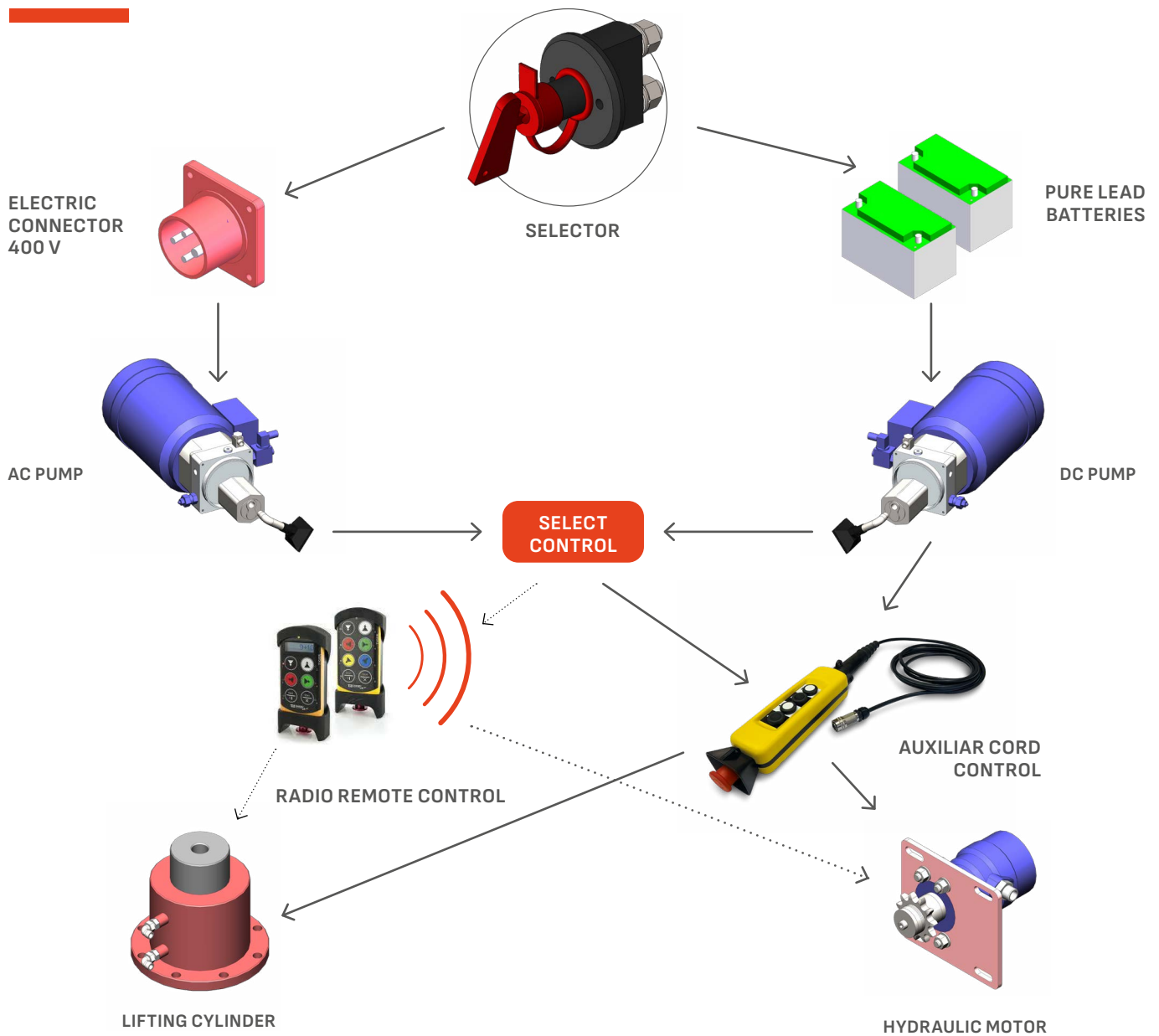

MACHINE MOVERS ACCESORIES AND SPARE PARTS

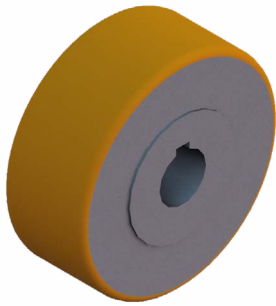

CH
Trolley traction wheel.



RD
Rear-trolley wheel
with bearing.



POLYURETHANE WHEELS

In case the floor is very slippery it is recommended to use polyurethane wheels (in combination with polyamide wheels) for better traction.

| CODE | DESCRIPTION (WHEEL / PIN) |
|------------|---------------------------|
| 801PU200CH | 200 x 100 / 45 |
| 801PU200RD | 200 x 100 / 45 |
| 801PU250CH | 200 x 100 / 60 |
| 801PU250RD | 200 x 100 / 60 |

AUXILIARY BATTERY BOX

All TBC trolleys are supplied with a battery box for continuous use of approximately 45-60 min approx. This time may vary depending on the conditions of use, load, type of floor, etc.

The auxiliary battery box is a box with wheels for quick change of the supplied with the original trolley, so that we double the working time.

The change can be made in one minute.

| CODE | DESCRIPTION |
|--------------|-----------------------|
| 801TBC1CBAUX | Auxiliary Battery Box |

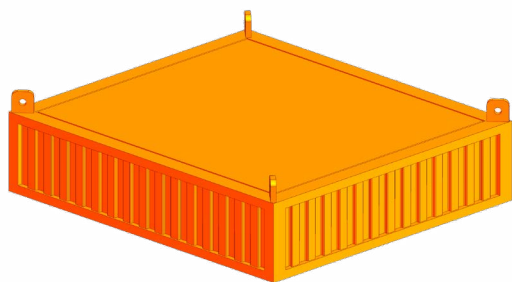

TRANSPORT BOXES

We supply all our trolleys with treated wooden box (not included in the price of the trolley) with cover, for better transport and handling.

But we can design any type of box, metallic for example, for better storage.

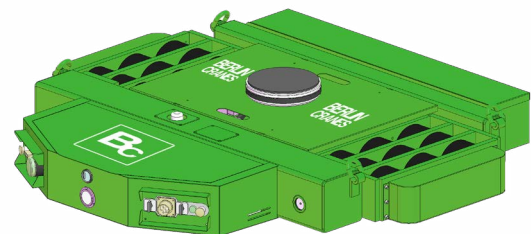

PAINTING. FINISH. SERIGRAPHY.

We offer you the possibility to customize your product by choosing the RAL paint you wish, serigraphy with your company logo, etc...

MACHINE MOVERS PORTFOLIO

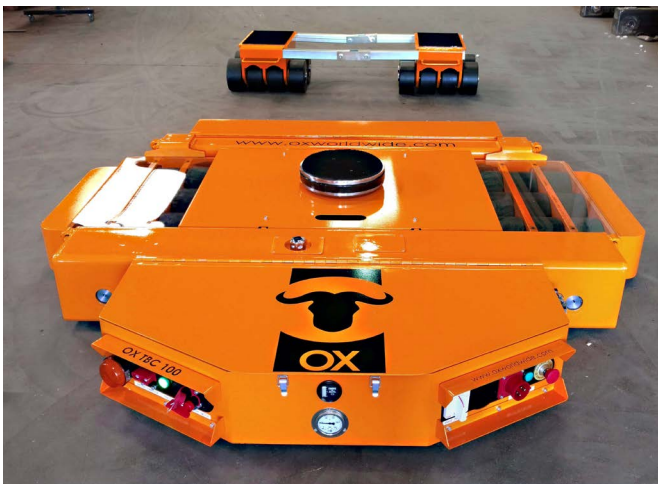

TECHNICAL FEATURES

- Rotating trolley (rotates 360°)
- Mobile platform with free wheels
- Loads from 4 to 6 tons
- It can be combined with manual trolleys
- Polyamide wheels
- It is recommended the transported load to be two thirds of the capacity of the set of rotating trolleys chosen by the customer
- The transported load must cover at least 70% of the support rubber surface (dimension D) and the weight must be centered
- The rotating trolleys have a Ø20mm central hole that allows the customer to fix the load to the device. As well as a lateral hole of Ø22mm to place a shackle of 3.25t for handling the trolley with no load on it

OPTIONS

- Polyurethane wheels (changes slightly the dimensions but not the capacity)
- Galvanized finish.
- Other dimensions can be manufactured under request

| CODE | DESCRIPTION | WLL (t) | PLATFORM DIMENSIONS (mm) | | | | NUMBER AND MATERIAL OF WHEELS | WHEEL DIMENSIONS Ø x E (mm) | WEIGHT (kg) |
|----------|--------------------------|---------|--------------------------|-----|-----|------|-------------------------------|-----------------------------|-------------|
| | | | A | B | C | D | | | |
| 801CG240 | OX-CG 4 Rotating Trolley | 4 | 380 | 425 | 115 | Ø200 | 8 polyamide | ø 85 x 40 | 31 |
| 801CG260 | OX-CG 6 Rotating Trolley | 6 | 430 | 475 | 120 | Ø200 | 12 polyamide | ø 85 x 40 | 48 |

4t OX-CG 4 Rotating Trolley



6t OX-CG 6 Rotating Trolley

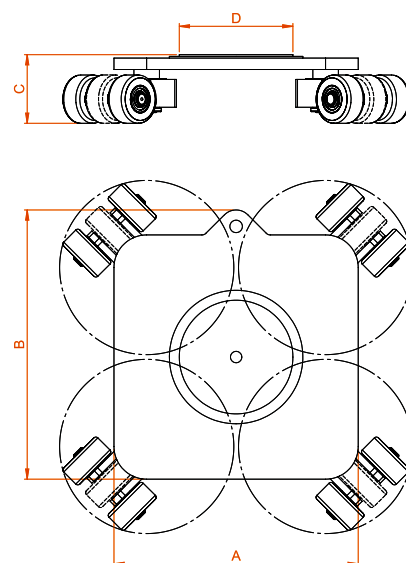
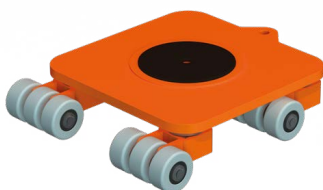

MACHINE MOVERS

ROTATING TROLLEYS

FEATURES

POSSIBLE USES

It is mandatory to use, at least, three points of support and the center of gravity has to be known and centered. You can combine the manual trolleys and the rotating trolleys.

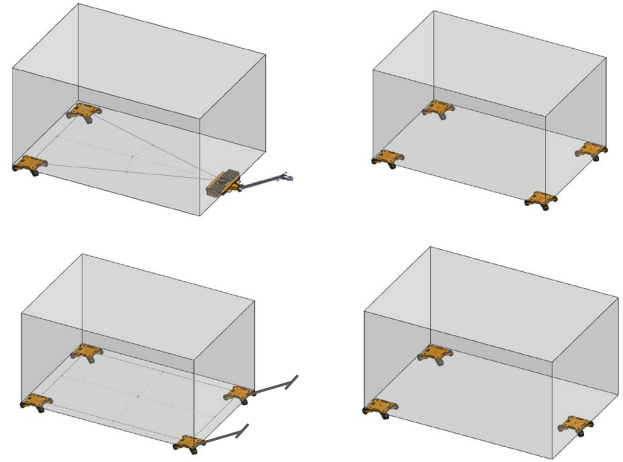

INCLUDED ACCESSORIES



CFCG200300
Smooth rubber



CFCG200400
Polyamide wheel

OPTIONAL ACCESSORIES

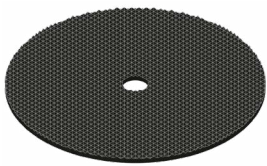

CFCG200301
Studded rubber

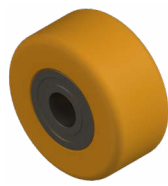

CFCG200401
Polyurethan wheel

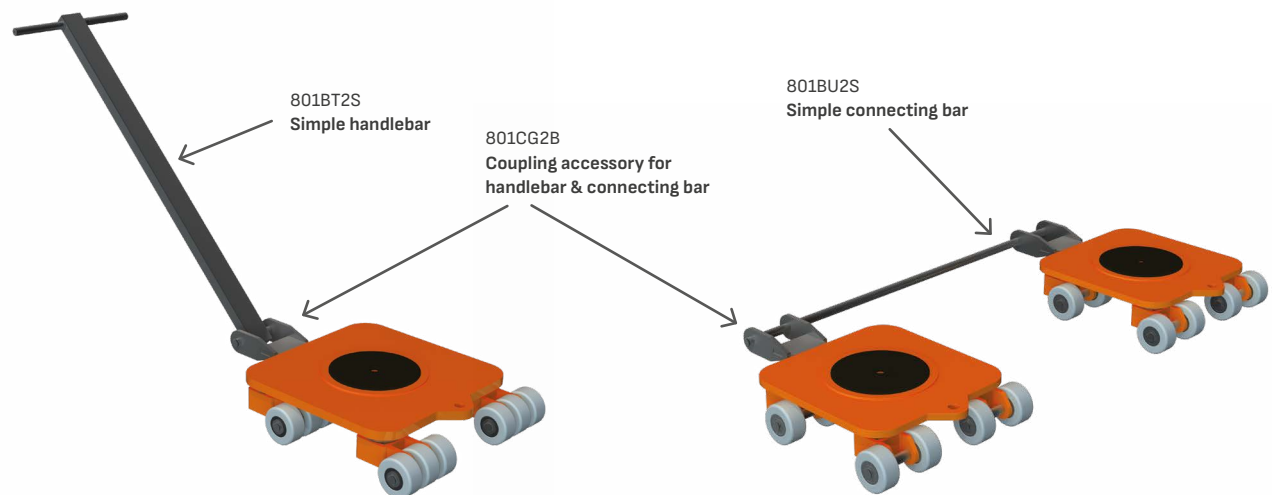

OX & RUD LIFTING SOLUTIONS, S.L.

OX, as a brand of the CFB group, was created in 1993, and in 2024 we joined a huge company, RUD Ketten Rieger & Dietz GmbH u. Co. KG., with the mission of offering and bringing to all countries the best solutions for the transport and lifting of loads in a controlled and safe way in any industrial, naval, railway, wind, oil & gas, offshore, automotive, aeronautical and small industries. Now, more than ever, closer to the customer, with distributors and branches on all five continents.

At OX & RUD, engineering, experience and advice are the bases of our quality.

OX & RUD, now bigger, stronger, better.



CERTIFICATES

We have managed to manufacture and distribute machinery that meets the highest standards.

For this, it is an essential requirement to pass all quality controls, which is why we have the following certifications:

- ISO 9001:2015
- EN ISO 3834-2:2006 (Welding)

OX & RUD is Lloyd Register Quality Assurance certified, in order to comply with all regulations, standards and norms of the European Union



“Our priority is to provide effective, profitable and safe solutions, to ensure long-term business relationships, through customer satisfaction”.

Emilio Blasco
Founder

**YOUR TRUSTED
PARTNER FOR
HEAVY LIFTING
SOLUTIONS**

LIFTING SOLUTIONS

bedsab@bedsab.se
08 - 714 54 30
031 - 761 60 60
www.bedsab.se

BEDSAB